

TOSVERT™ VF-S15

ATEX Guide

ATEX applications in explosive gas atmosphere
or in the presence of combustible dust

Toshiba Industrial Products and Systems Corporation

—Contents—

1.	Functional Safety and ATEX applications	1
1.1	General	1
2.	Applications for explosive atmosphere (ATEX)	3
2.1	Classification of ATEX Zones	3
2.2	General	3
2.3	Identification of the ATEX marking	4
3.	Schemes of cabling for ATEX applications	5
3.1	General	5
3.2	ATEX periodic test.....	5
3.3	Schemes for ATEX installation No.1	6
3.4	Schemes for ATEX installation No.2	7
3.5	Schemes for ATEX installation No.3	8
3.6	Schemes for ATEX installation No.4	9
3.7	Schemes for ATEX installation No.5	10
3.8	Schemes for ATEX installation No.6	11
3.9	Schemes for ATEX installation No.7	12
3.10	Schemes for ATEX installation No.8	13

1. Functional Safety and ATEX applications

1.1 General

The variable speed drives TOSVERT VF-S15 integrate the “Safe Torque Off” safety function which prohibits unintended equipment operation. The motor no longer produces torque. The use of the “Safe Torque Off” Safety function allows the drive to be installed as a part of the safety-related electrical, electronic and programmable electronic control systems, dedicated to the safety of a machine or an industrial process. This safety function complies with the standard for safety of machinery EN ISO 13849-1 category 3 PLd (EN 954-1, category 3). It complies also with the standard for functional safety IEC/EN 61508 and with the power drive systems’ product standard IEC/EN 61800-5-2, SIL2 capability.

The use of the “Safe Torque Off” safety function also allows TOSVERT VF-S15 variable speed drives to control and command motors installed in explosive atmospheres (ATEX).

Protection of the ATEX motor:

The STO input is connected to the switching system which is embedded in the thermal detector to the ATEX motor (or connected to the switching system of the control system if ATEX sensor or PTC type are used).

TOSVERT VF-S15 listed on table 1 integrates the “Safe Toque Off” function.

Table 1

Input voltage class	Inverter type
3-phase 200V to 240V	VFS15-2002PM__/-W1/Y-A*
	VFS15-2004PM__/-W1/Y-A*
	VFS15-2007PM__/-W1/Y-A*
	VFS15-2015PM__/-W1/Y-A*
	VFS15-2022PM__/-W1/Y-A*
	VFS15-2037PM__/-W1/Y-A*
	VFS15-2055PM__/-W1/Y-A*
	VFS15-2075PM__/-W1/Y-A*
	VFS15-2110PM__/-W1/Y-A*
	VFS15-2150PM__/-W1/Y-A*
1-phase 200V to 240V	VFS15S-2002PL__/-W1/Y-A*
	VFS15S-2004PL__/-W1/Y-A*
	VFS15S-2007PL__/-W1/Y-A*
	VFS15S-2015PL__/-W1/Y-A*
	VFS15S-2022PL__/-W1/Y-A*

3-phase 380V to 500V	VFS15-4004PL__/-W1/Y-A*
	VFS15-4007PL__/-W1/Y-A*
	VFS15-4015PL__/-W1/Y-A*
	VFS15-4022PL__/-W1/Y-A*
	VFS15-4037PL__/-W1/Y-A*
	VFS15-4055PL__/-W1/Y-A*
	VFS15-4075PL__/-W1/Y-A*
	VFS15-4110PL__/-W1/Y-A*
	VFS15-4150PL__/-W1/Y-A*
3-phase 380V to 500V	VFS15-4004PL1__/-W1/Y-A*
	VFS15-4007PL1__/-W1/Y-A*
	VFS15-4015PL1__/-W1/Y-A*
	VFS15-4022PL1__/-W1/Y-A*
	VFS15-4037PL1__/-W1/Y-A*
3-phase 525V to 600V	VFS15-6015P__/-W1/Y-A*
	VFS15-6022P__/-W1/Y-A*
	VFS15-6037P__/-W1/Y-A*
	VFS15-6055P__/-W1/Y-A*
	VFS15-6075P__/-W1/Y-A*
	VFS15-6110P__/-W1/Y-A*
	VFS15-6150P__/-W1/Y-A*

(*)The references followed by “Y-A38”, “Y-A65”, “Y-A66” and “Y-A67” don’t conform.

2. Applications for explosive atmosphere (ATEX)

2.1 Classification of ATEX Zones

- The European directive 1999/92/EC (also called ATEX 137, or directive for protection of workers) classifies the ATEX zones and the type of products compatible with. The user should define the ATEX zone in which the ATEX motor will be installed.
- The variable speed drive VF-S15 shall always be installed into a safe area, outside the hazardous ATEX zone. Different schemes for installation are suggested in this document. They are compatible for the use of motors in ATEX zones 2 ; 22 ; 1 or 21. The table below summarises characteristics related to each ATEX zone.

Atmosphere	Zone	Definition	Presence of explosive atmosphere per year
Gas	0	Explosive atmosphere is present continuously, for long periods or frequently due to malfunctions	> 1000 h
Dust	20		
Gas	1	Explosive atmosphere is likely to occur due to expected malfunctions	10 – 1000 h
Dust	21		
Gas	2	Explosive atmosphere is unlikely to occur or, if occurring, is likely to only be of short duration and not in normal duty	< 10 h
Dust	22		

Note : Neither electrical equipments nor motors can be installed into ATEX zone 0 or 20.

2.2 General

The European directive 2014/34/EU (also called ATEX 95, or product directive) defines applicable requirements for ATEX products and requirements for procedure of certification.

OEMs, installers, users are responsible for the choice and the commissioning of the products they use in order to realise the ATEX protection of systems that they design or systems that they implement.

- The motor is to be ATEX certified and to be compatible for use in zone 2/22 or 1/21.
- The motor shall be equipped with thermal detector(s) with embedded switching system ATEX certified, or shall be equipped with thermal detector(s) ATEX certified, associated to a control unit, which is to be also ATEX certified.

Warning : Usually, the control unit are designed to be used outside the hazardous ATEX zone. Then it is possible to install the control unit near the variable speed drive, into the safe area.

The switching system, embedded into the thermal detector, or included into the control unit of the thermal protection of the ATEX motor, shall be connected to the STO input of the variable speed drive VF-S15. When the excessive temperature of the ATEX motor is reached, the control system trips automatically the Safe Torque Off safety function. The electrical power of the motor is removed in order to guarantee a temperature of the motor frame below the dangerous temperature for the gas or the dust atmosphere in which the ATEX motor is installed.

When the ATEX application needs to apply the "Safe Torque Off" safety function, a safety module (type Preventa), is to be used. The suggested schemes describe how the switching system, embedded into the thermal detector or included into the control unit, is connected to the safety module. The output of the safety module is to be connected to the STO input of the variable speed drive VF-S15.

Remark : Stopping category related to the IEC/EN 60204-1

The schemes for installation, suggested in this document, show the use of a safety module (type Preventa XPS-AC) in combination with an ATEX application, with the use of the safety function when the stopping category 0, related to IEC/EN 60204-1, is required.

The user should take care for using a temporised safety module (type Preventa XPS-ATE), in combination with the ATEX application when the stopping category 1, related to IEC/EN 60204-1, is required.

2.3 Identification of the ATEX marking

The variable speed drive VF-S15, ATEX certified, can be recognised by the specific marking reproduced hereafter:

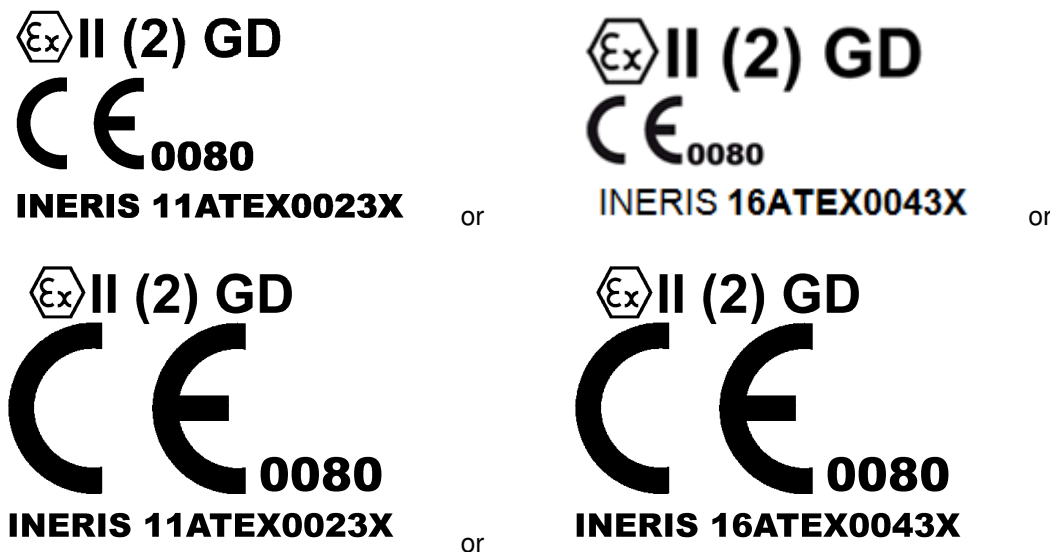

Single marking complies with all of applications covered by the ATEX certification of the drive.

0080 is the identification number of the notified body INERIS, which has delivered the notifications for systems of production quality assurance of production lines for drives, in compliance with the standard EN 50980.

INERIS 11ATEX0023X or 16ATEX0043X is the identification code of the certification report delivered by the notified body INERIS to demonstrate the compliance of the variable speed drive with the requirements of the ATEX 2014/34/EU directive.



is the logo related to the identification of an ATEX product

II is related to the use of products for ATEX application in surface industries. (ATEX applications for mines industries are prohibit)

(2) Parenthesis identify the variable speed drive VF-S15 as a product associated with the control & command of an ATEX motor installed into a hazardous zone. The number 2 identifies the ATEX motor as a product of category 2 for use into ATEX zones 1 or 21. Motors of category 3 for use into ATEX zones 2 or 22 are also covered by this marking.

G for Gas, is related to ATEX applications into atmospheres with explosive gas.

D for Dust, is related to ATEX applications into atmospheres with a mixture of explosive dust.

3. Schemes of cabling for ATEX applications

3.1 General

Installation and commissioning of apparatus, including connection of cables shall comply with the local regulations where products are installed. Requirements provided by the ATEX standards for installation should be fulfilled, when applicable:

- IEC 60079-14 for applications into atmospheres with explosive gas.
- IEC 61241-14 for applications into atmospheres with presence of combustible dust.

in ATEX zones 1 or 2, for applications into atmospheres with explosive gas, the requirements of the IEC 60079-14 standard for installation are applicable.

IEC 60079-14: Electrical apparatus for explosive gas atmospheres – Part 14: Electrical installations in hazardous areas (other than mines).

in ATEX zones 21 or 22, for applications into atmospheres with presence of combustible dust, the requirements of the IEC 61241-14 standard for installation are applicable.

IEC 61241-14 : Electrical apparatus for use in the presence of combustible dust – Part 14: Selection and installation

Schemes suggested in this document for installation and commissioning of variable speed drive VF-S15 for ATEX applications are taking into account the different types of thermal detectors used with the ATEX motor.

- If the ATEX motor, installed into an hazardous zone 2 or 22, includes at least one thermal detector with an embedded switching system (as defined in 3.1.4 of the IEC/EN 60947-8 standard) then, the switching system of this thermal detector can be directly connected to the STO input of the variable speed drive. See Scheme for ATEX installation No.1 page 5 and Scheme for ATEX installation No.2 page 6.
- If the ATEX motor, installed into an hazardous zone 1 or 21, includes at least two thermal detectors with an embedded switching system (as defined in 3.1.4 of the IEC/EN 60947-8 standard) then, the switching system of these thermal detectors can be directly connected in series to the STO input of the variable speed drive. See Scheme for ATEX installation No.5 page 9 and Scheme for ATEX installation No.6 page 10.
- If the ATEX motor, installed into an hazardous zone 2 or 22, includes at least one thermal detector without any embedded switching system (for example a PTC sensor), then this one thermal detector shall be connected to a control unit (as defined in 3.1.15 of the IEC/EN 60947-8 standard). The control unit is a device which converts into a switching function the variation of the characteristic of a thermal detector. See Scheme for ATEX installation No.3 page 7 and Scheme for ATEX installation No.4 page 8.

Remark : The same requirement applies to thermal detectors without any embedded switching system for motors installed into an hazardous zone 1 or 21. See Scheme for ATEX installation No.7 page 11 and Scheme for ATEX installation No.8 page 12.

3.2 ATEX periodic test

The complete safety loop (which starts from the ATEX motor thermal sensor up to the “ Safe Torque Off” safety function embedded in the drive), shall be activated at least once a year for preventive maintenance purposes, in order to check that the electrical power is always automatically removed from the motor in case of excessive temperature.

3.3 Scheme for ATEX installation No.1

ATEX motor into Zone 2 or 22:

STO input used for protection of the ATEX motor only:

Thermal protection of the ATEX motor by using of an ATEX thermal detector with embedded switching system.

•Connection in source mode (common: P24)

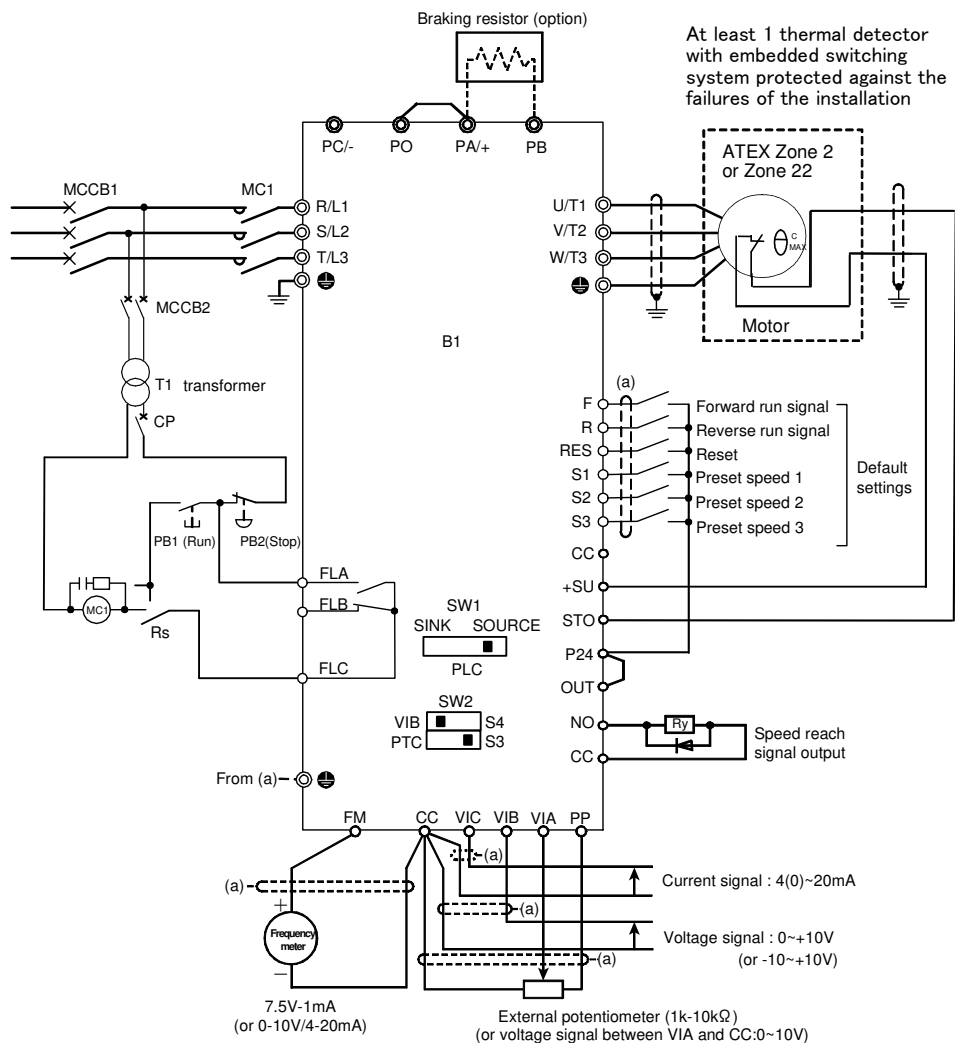

Symbols	Description
B1	Inverter VF-S15
MCCB1	Circuit breaker
MC1	Magnetic conductor
MCCB2	Circuit breaker for control transformer
T1	Control transformer 400/200V (For 400V class only)
CP	Circuit protector
PB1	Push button switch (Run)
PB2	Push button switch (Stop/emergency stop)
Rs	Control relay

3.4 Scheme for ATEX installation No.2

ATEX motor into Zone 2 or 22:

STO input used for protection of the ATEX motor and for the functional safety of Category 3 PLd (EN ISO 13849-1) and for SIL 2 (IEC/EN 61508 or IEC/EN 61800-5-2) in stopping category 0 according to IEC/EN 60204-1:

Thermal protection of the ATEX motor by using of an ATEX thermal detector with embedded switching system.

•Connection in source mode (common: P24)

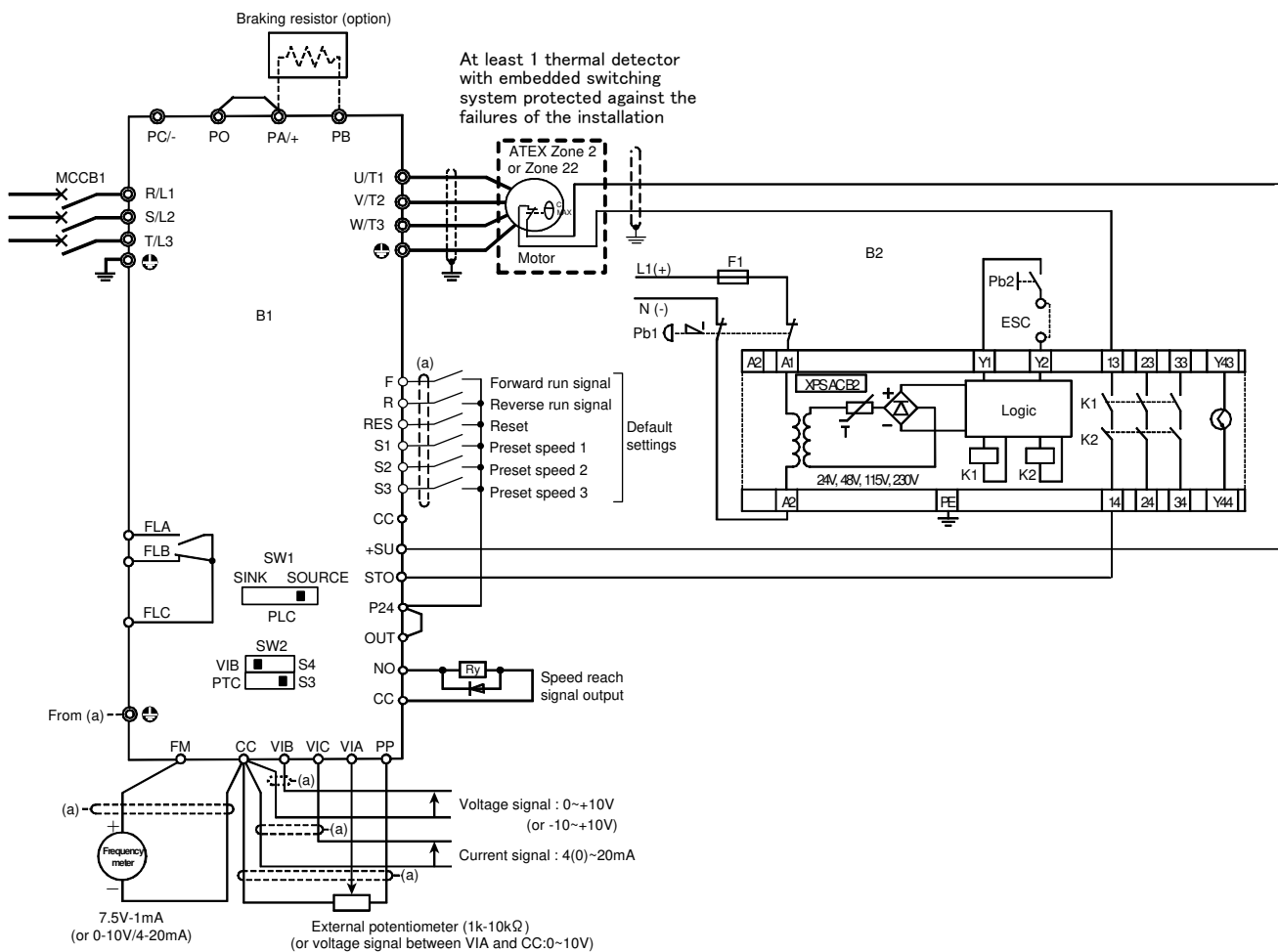

Symbols	Description
B1	Inverter VF-S15
MCCB1	Circuit breaker
B2	Safety relay: XPS-AC (manufactured by Schneider Electric)
F1	Fuse
Pb1	Push button switch 2b contact (for emergency stop)
Pb2	Push button switch (for reset and start)

3.5 Scheme for ATEX installation No.3

ATEX motor into Zone 2 or 22:

STO input used for protection of the ATEX motor only:

Thermal protection of the ATEX motor by using of an ATEX thermal detector (PTC type, without embedded switching system), and a control unit for the PTC conversion, including the switching system.

•Connection In source mode (common: P24)

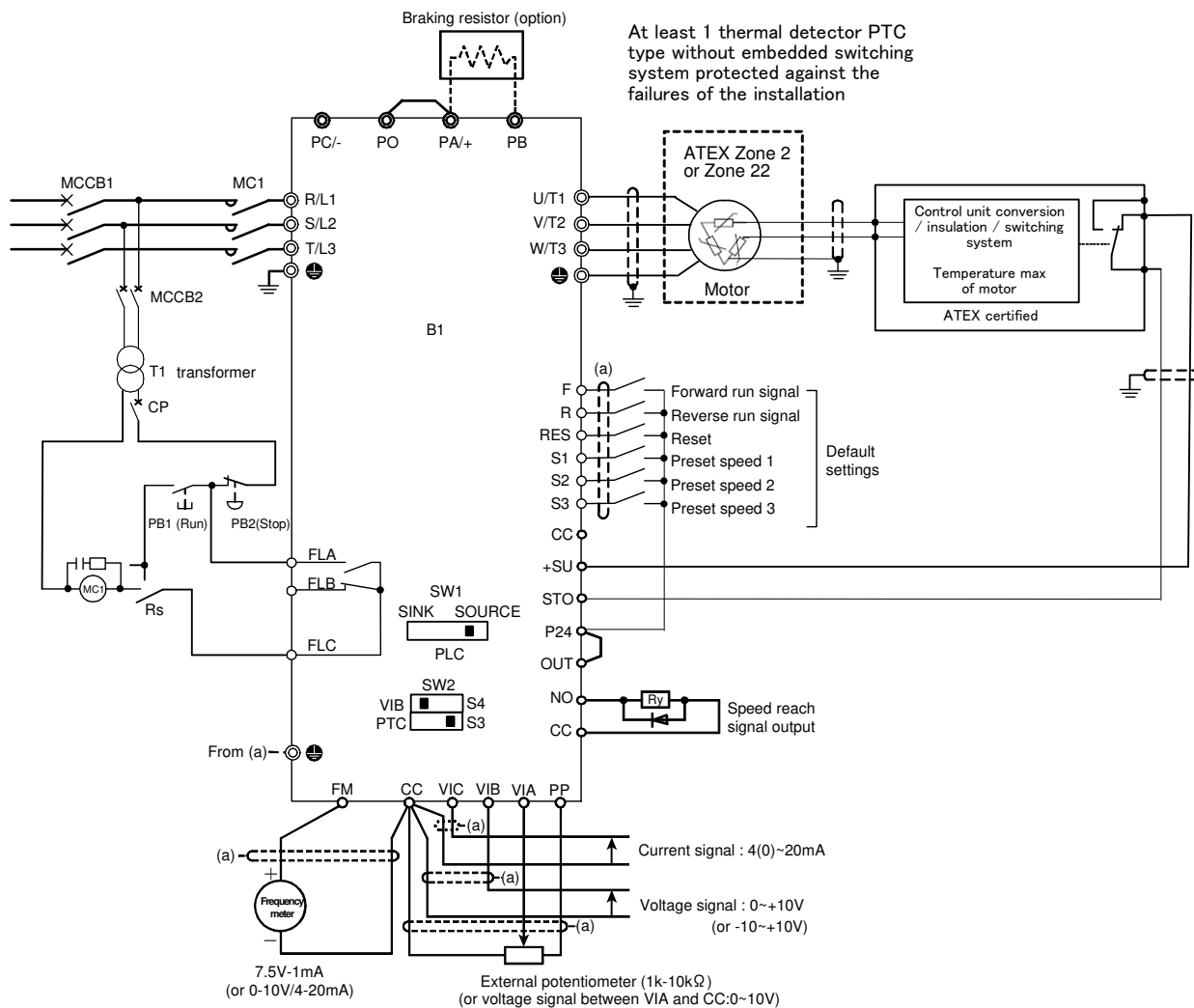

Symbols	Description
B1	Inverter VF-S15
MCCB1	Circuit breaker
MC1	Magnetic conductor
MCCB2	Circuit breaker for control transformer
T1	Control transformer 400/200V (For 400V class only)
CP	Circuit protector
PB1	Push button switch (Run)
PB2	Push button switch (Stop/emergency stop)
Rs	Control relay

3.6 Scheme for ATEX installation No.4

ATEX motor into Zone 2 or 22:

STO input used for protection of the ATEX motor and for the functional safety of Category PLd (EN ISO 13849-1) and for SIL 2 (IEC/EN 61508 or IEC/EN 61800-5-2) in stopping category 0 according to IEC/EN 60204-1:

Thermal protection of the ATEX motor by using of an ATEX thermal detector (PTC type, without embedded switching system), and a control unit for the PTC conversion, including the switching system.

•Connection in source mode (common: P24)

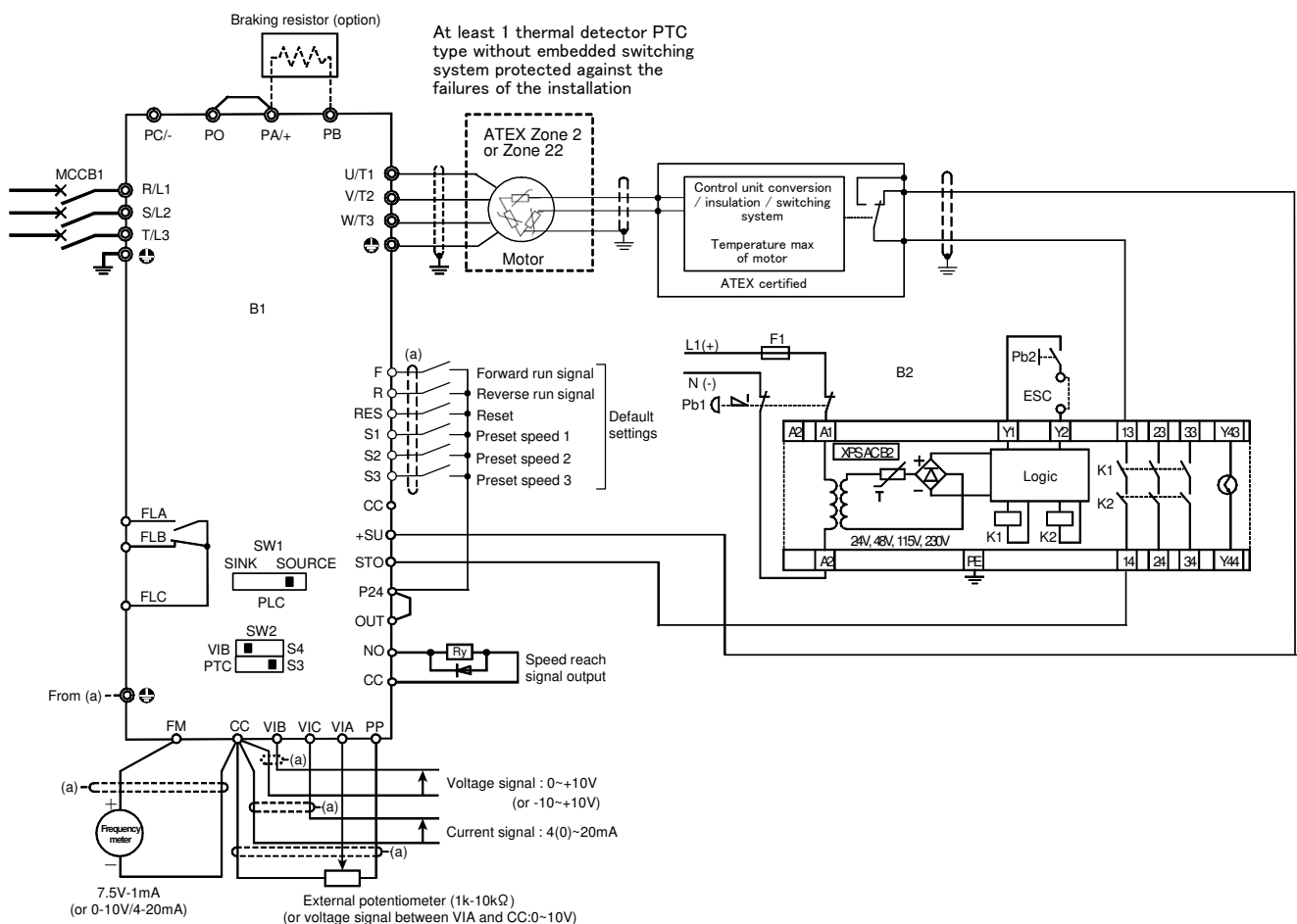

Symbols	Description
B1	Inverter VF-S15
MCCB1	Circuit breaker
B2	Safety relay: XPS-AC (manufactured by Schneider Electric)
F1	Fuse
Pb1	Push button switch 2b contact (for emergency stop)
Pb2	Push button switch (for reset and start)

3.7 Scheme for ATEX installation No.5

ATEX motor into Zone 1 or 21:

STO input used for protection of the ATEX motor only:

Thermal protection of the ATEX motor by using of ATEX thermal detectors with embedded switching system.

•Connection in source mode (common: P24)

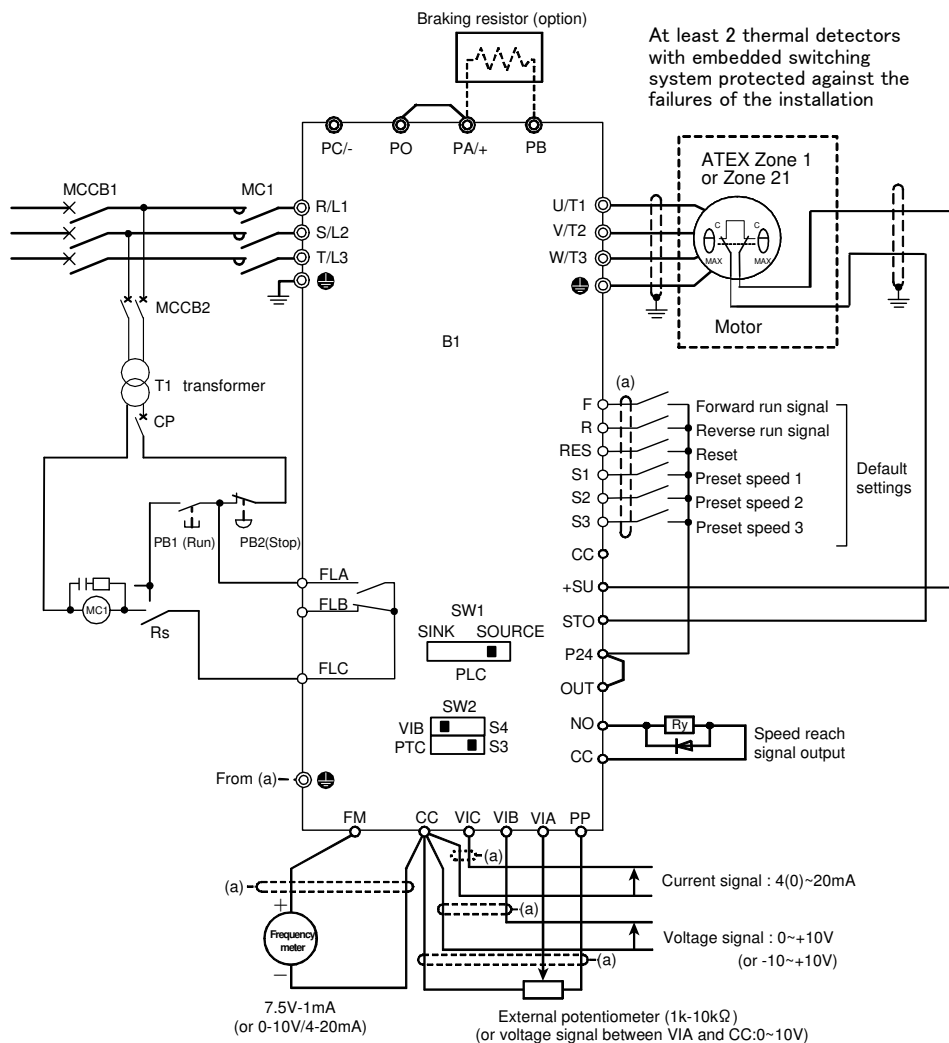

Symbols	Description
B1	Inverter VF-S15
MCCB1	Circuit breaker
MC1	Magnetic conductor
MCCB2	Circuit breaker for control transformer
T1	Control transformer 400/200V (For 400V class only)
CP	Circuit protector
PB1	Push button switch (Run)
PB2	Push button switch (Stop/emergency stop)
Rs	Control relay

3.8 Scheme for ATEX installation No.6

ATEX motor into Zone 1 or 21:

STO input used for protection of the ATEX motor and for the functional safety of Category 3 PLd (EN ISO 13849-1) and for SIL 2 (IEC/EN 61508 or IEC/EN 61800-5-2) in stopping category 0 according to IEC/EN 60204-1:

Thermal protection of the ATEX motor by using of ATEX thermal detectors with embedded switching system.

•Connection in source mode (common: P24)

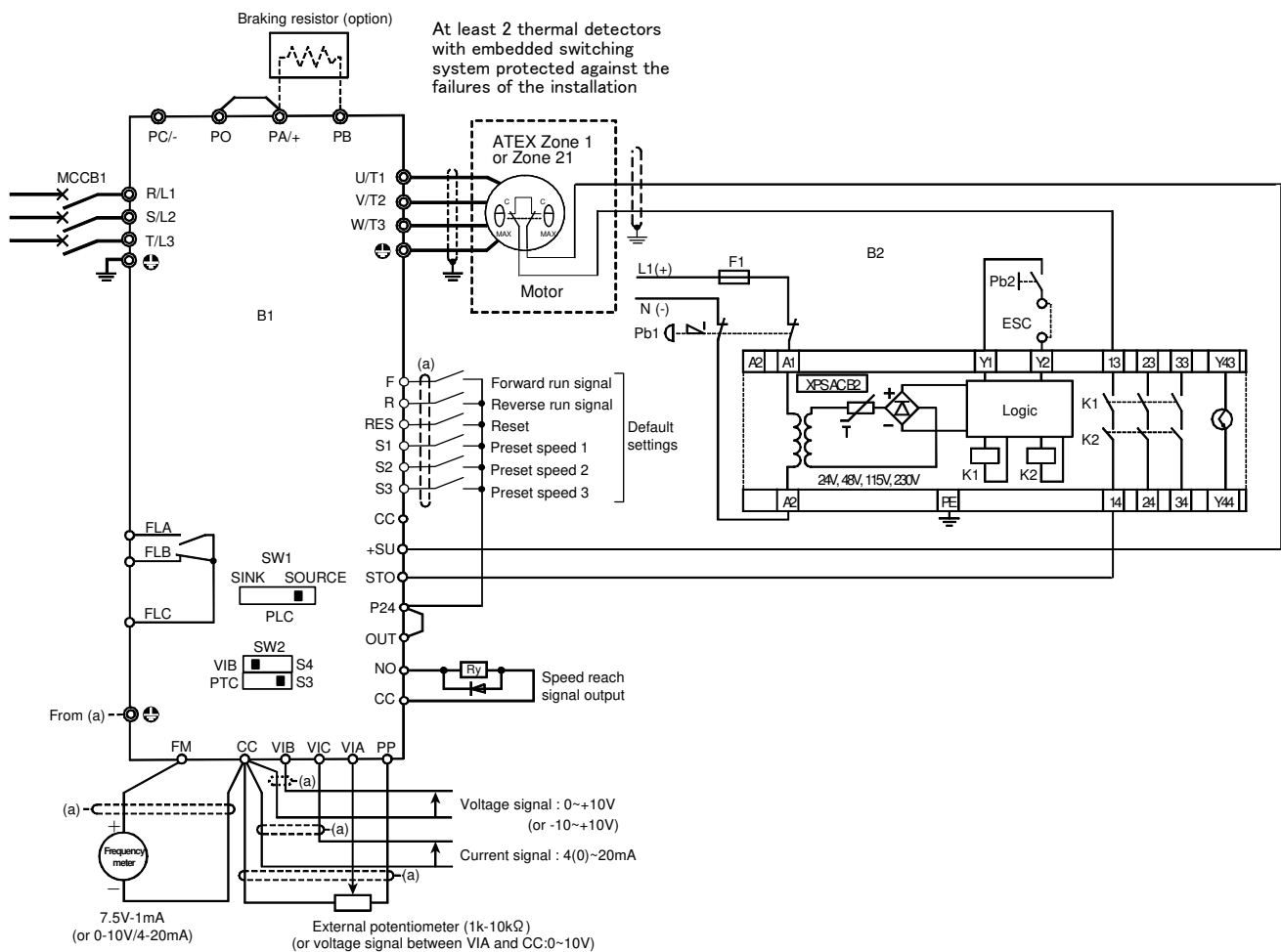

Symbols	Description
B1	Inverter VF-S15
MCCB1	Circuit breaker
B2	Safety relay: XPS-AC (manufactured by Schneider Electric)
F1	Fuse
Pb1	Push button switch 2b contact (for emergency stop)
Pb2	Push button switch (for reset and start)

3.9 Scheme for ATEX installation No.7

ATEX motor into Zone 1 or 21:

STO input used for protection of the ATEX motor only:

Thermal protection of the ATEX motor by using of ATEX thermal detectors (PTC type, without embedded switching system), and a control unit for the PTC conversion, including the switching system.

•Connection in source mode (common: P24)

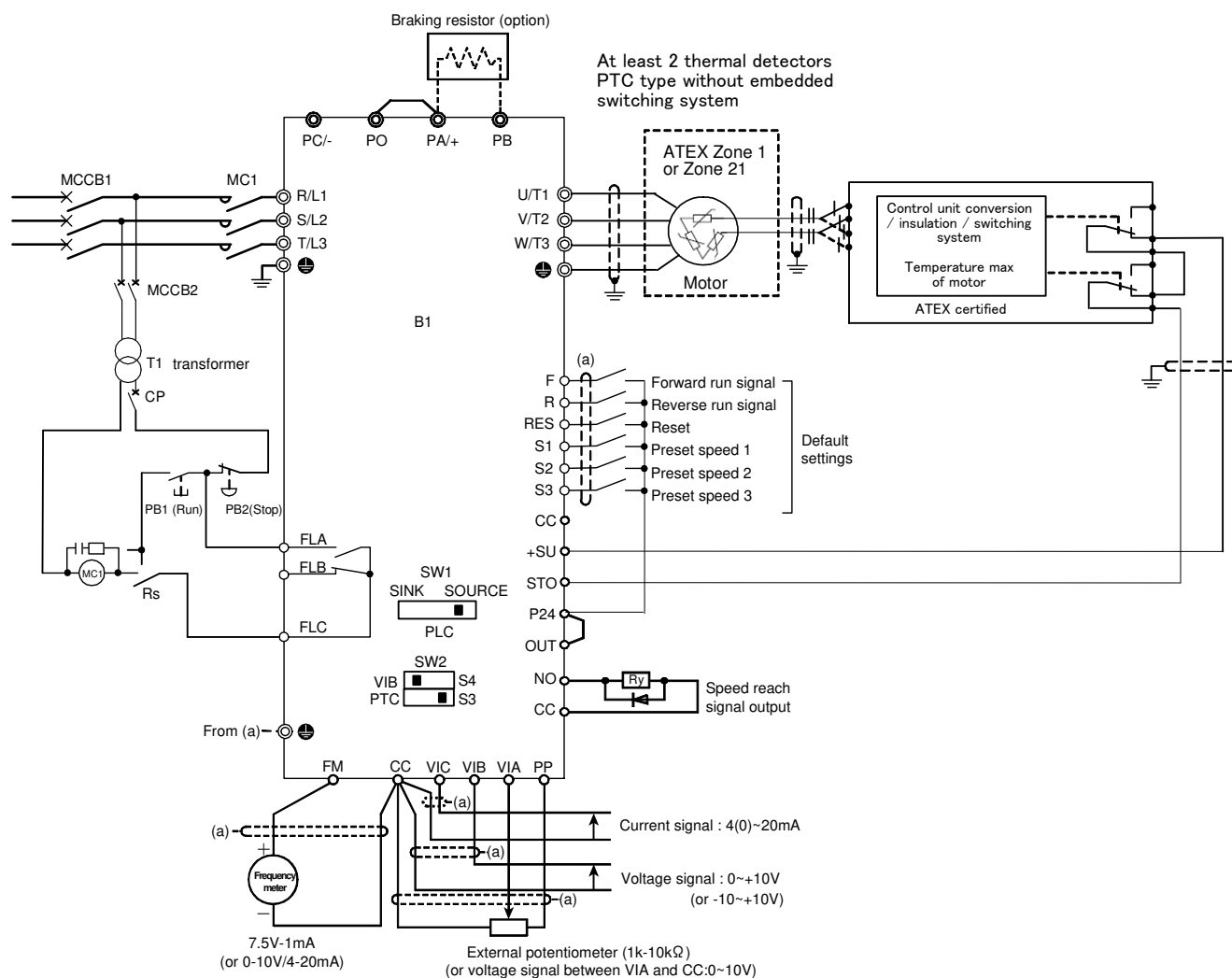

Symbols	Description
B1	Inverter VF-S15
MCCB1	Circuit breaker
MC1	Magnetic conductor
MCCB2	Circuit breaker for control transformer
T1	Control transformer 400/200V (For 400V class only)
CP	Circuit protector
PB1	Push button switch (Run)
PB2	Push button switch (Stop/emergency stop)
Rs	Control relay

3.10 Scheme for ATEX installation No.8

ATEX motor into Zone 1 or 21:

STO input used for protection of the ATEX motor and for the functional safety of Category 3 PLd (EN ISO 13849-1) and for SIL 2 (IEC/EN 61508 or IEC/EN 61800-5-2) in stopping category 0 according to IEC/EN 60204-1:

Thermal protection of the ATEX motor by using of ATEX thermal detectors (PTC type, without embedded switching system), and a control unit for the PTC conversion, including the switching system.

▪Connection in source mode (common: P24)

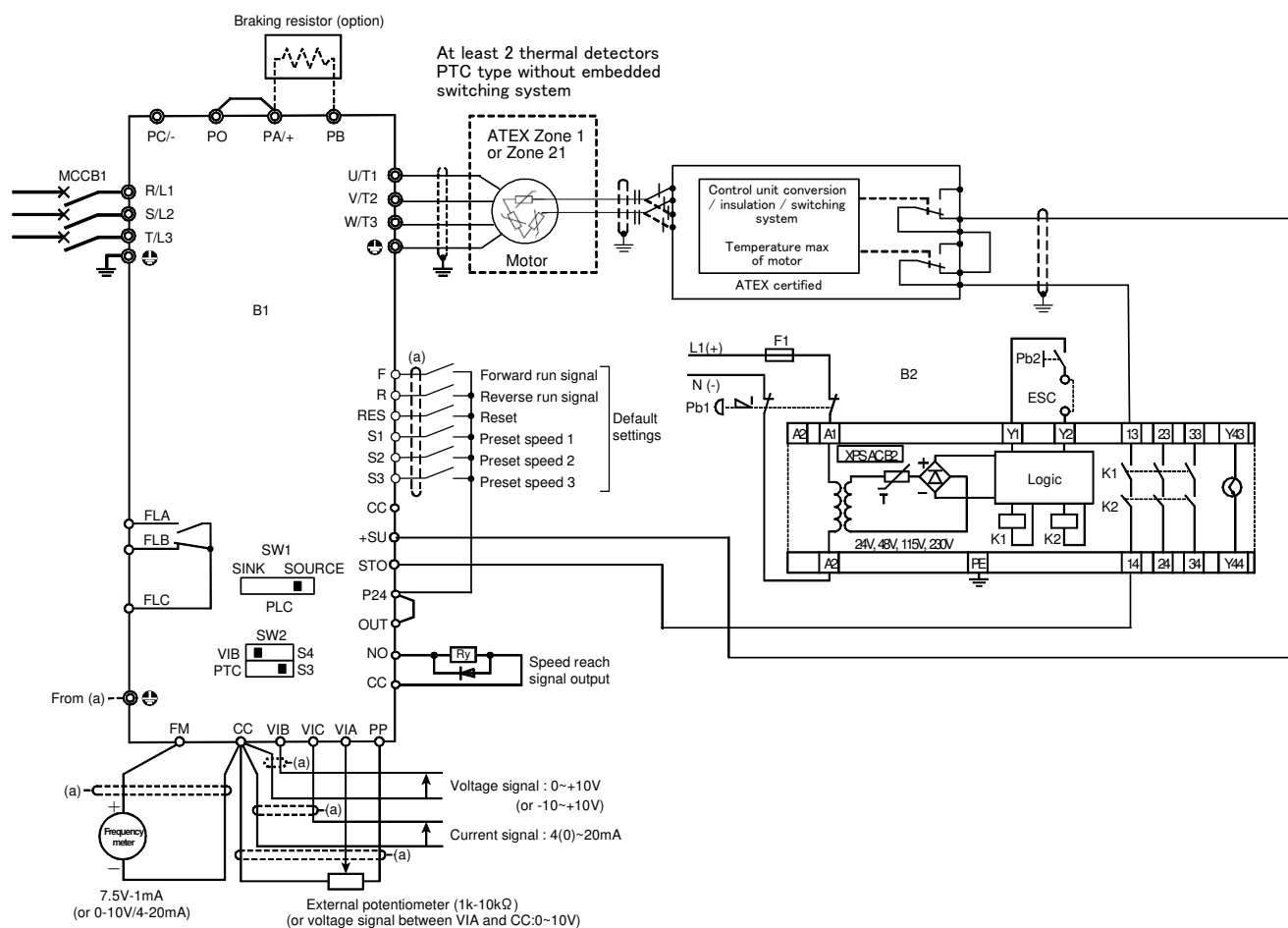

Symbols	Description
B1	Inverter VF-S15
MCCB1	Circuit breaker
B2	Safety relay: XPS-AC (manufactured by Schneider Electric)
F1	Fuse
Pb1	Push button switch 2b contact (for emergency stop)
Pb2	Push button switch (for reset and start)